



CHAPTER FIVE

Property Complex Address Directories

Contents:

- Address Directory Guidelines
- Entrance Islands into Residential Communities
- Apartment Monuments and Directories

Purpose:

A proper address directory placed at the entry of a complex aids all emergency responders attempting to find a location on a property with multiple buildings and/or suites (i.e., apartment complexes, hospital campuses).



ADDRESS DIRECTORY GUIDELINES

GENERAL

Approved graphic directories shall be provided at all driveway entrances for all multiple dwelling developments, mobile home parks, or when required by the Fire Marshal or Fire Code Official. Such directories shall be illuminated and conform to the Los Alamos Fire Department design standards and be approved by the Fire Marshal or Fire Code Official.

Prior to construction, plans shall be submitted to the Fire Marshal's Office for review.

DIMENSIONS

The number of buildings in the complex shall determine the minimum dimensions of the directory:

1. Complexes of 12 or fewer buildings require 3x3 feet (9 square feet)
2. Complexes of 13 to 30 buildings require 4x4 feet (16 square feet)
3. Complexes of 31 or more buildings require 5x5 feet (25 square feet)

FRAMING

Framing materials shall not encroach upon the face of the directory by more than one and one half (1½) inches. Stanchions or supports shall not be included in the required size of the directory.

PROTECTION

The directory shall be protected against vandalism and disfigurement by a clear polycarbonate cover, with a minimum of one-eighth ($\frac{1}{8}$) inch thickness, sealed to protect from weather.

ILLUMINATION

Address directories shall be illuminated, either internally or externally, utilizing white light. The directory must be illuminated from dusk to dawn.

INSTALLATION REQUIREMENTS

Support posts or stanchions shall be set in concrete. Directories with dimensions of 3x3 feet (9 square feet) shall be 36 inches above grade. Directories with dimensions of 4x4 feet (16 square feet) and 5x5 feet (25 square feet) shall be 24 inches above grade.

PROHIBITION

Information such as advertising or additional artwork shall not be permitted on the directory.



DEPICTIONS

All depictions must be clear, easily understood and legible from a distance of eight (8) feet. The directory shall depict structures, building numbers, units, apartment space numbers, tennis courts, swimming pools, canals, waterfronts, driveways, streets, laundry rooms, fire hydrants, and other areas determined by the Fire Marshal. The depictions shall comply with the following:

1. Directories shall be provided at all driveway entrances for all multiple dwelling developments, mobile home parks, or when required by the Fire Marshal. Such directories shall be illuminated and shall conform to the Los Alamos County design standards and must be approved by the Fire Marshal.
2. The name and address of the complex is required but shall not exceed ten percent (10%) of the total size of the site directory.
3. Swimming pools, canals, and waterway areas shall be translucent blue or as approved.
4. Tennis courts shall be translucent green or as approved.
5. Fire hydrants shall be one-fourth ($\frac{1}{4}$) inch diameter black circle filled with a translucent yellow center or as approved. The abbreviation "FH" must be affixed by the location of the fire hydrant on the directory.
6. The directory shall be properly oriented to the viewer with a red symbol, one (1) inch in diameter, with the words "You Are Here" affixed at the appropriate location on the directory.
7. There must be a north directional arrow affixed to the directory. This arrow must be a minimum of three (3) inches in size.
8. The colors used on the site directory may not be duplicated to represent more than one item.

SETBACKS

The directory shall be installed on the occupancy's property and at a location approved by the Fire Marshal as follows:

1. The directory shall be set back from the street or curbing at least 25 feet to allow emergency vehicles to be clear of the public right-of-way;
2. Shall not exceed a distance of four (4) feet from the edge of the property driveway facing the direction of oncoming traffic;
3. Shall not conflict with traffic visibility zones as provided for by other ordinances;
4. Shall be immediately visible and free from obstructions including architectural design and landscaping.



CORRIDOR SPREAD PLATE SAMPLE DETAIL

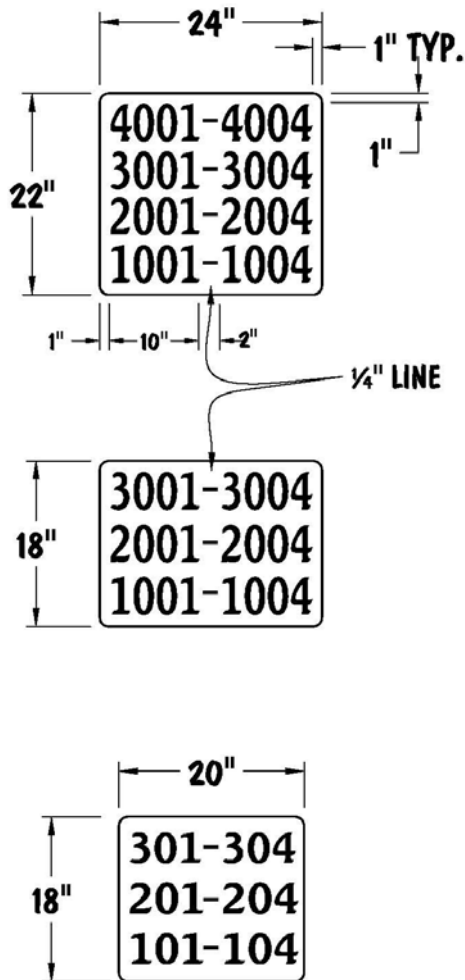

Number Size (Four Digit Plate) [Four Floors]

- 4" x 5/8" brush stroke
- 4 digit numbers – thousand series

Number Size (Four Digit Plate) [Three Floors]

- 4" x 5/8" brush stroke
- 3 digit numbers – hundred series

Number Size (Three Digit Plate) [Three Floors]

- 4" x 5/8" brush stroke
- 3 digit numbers – hundred series
- 101-199 number range



RESIDENTIAL COMMUNITY ENTRANCE ISLAND WITH AUTOMATIC GATES DETAIL

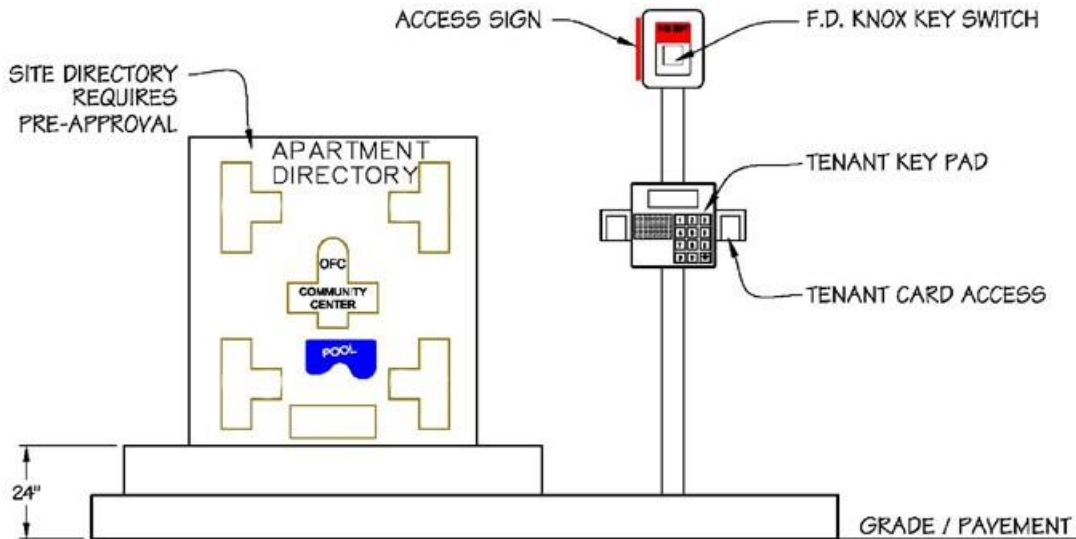

**ENTRANCE ISLAND
ELEV. DETAIL (FRONT VIEW)**

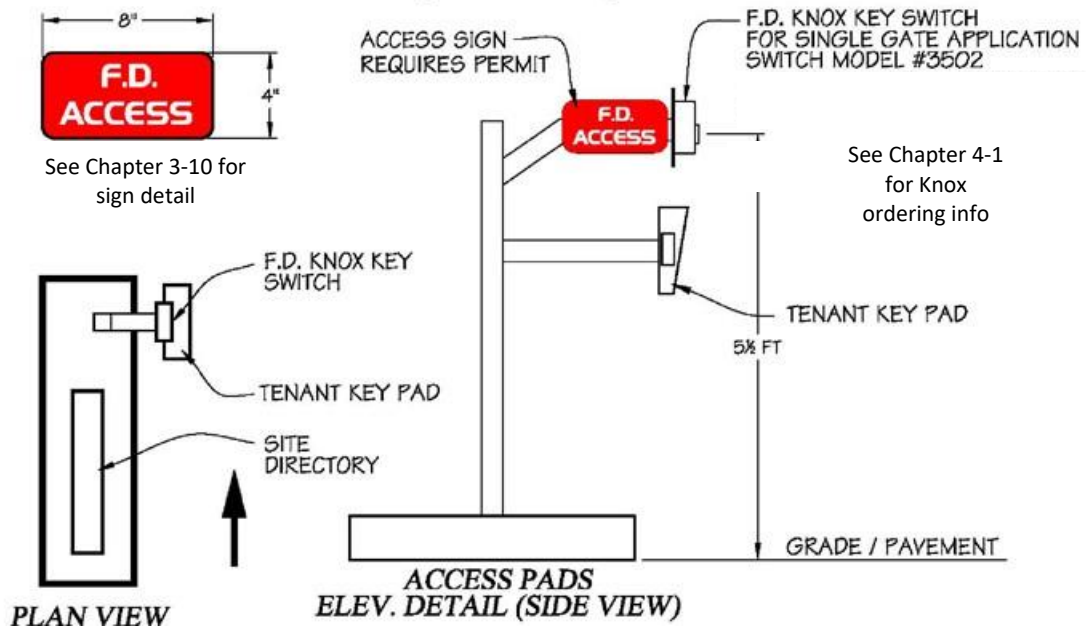



INTERNALLY ILLUMINATED SITE DIRECTORY DETAIL

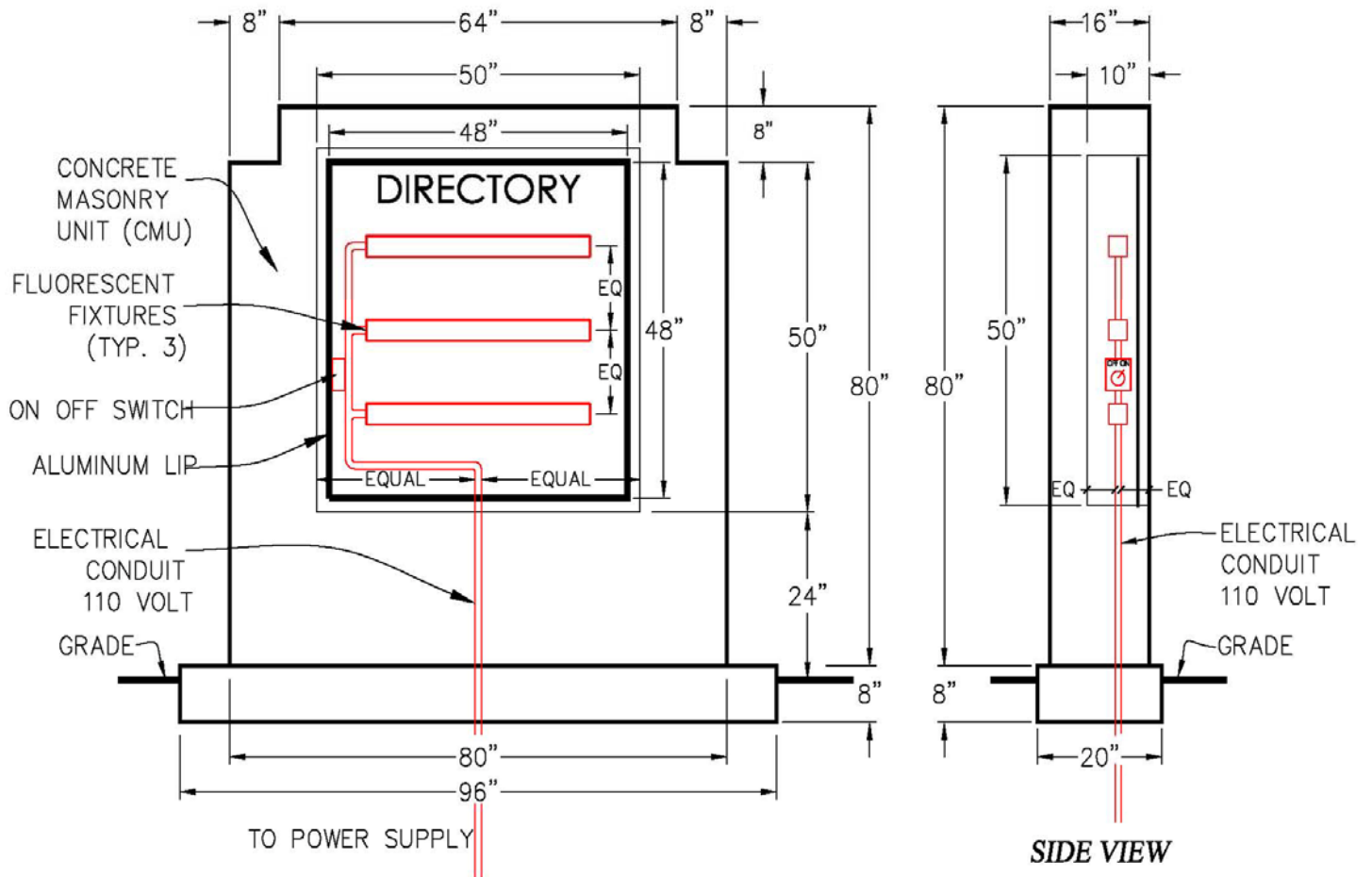

1. Include a photoelectric cell.



ADDRESS DIRECTORY EXAMPLE

D I R E C T O R Y

Mariposa Cliffs

123 Monument Crossing
Los Alamos, NM

505-555-1234

KEY:
● = FIRE HYDRANT

NORTH



APARTMENT COMPLEX MONUMENT EXAMPLE





APARTMENT COMPLEX MONUMENT EXAMPLE





COMPLEX DIRECTORY EXAMPLE

Keres TOWN SQUARE

