



# **CHAPTER 7**

## **Manual Vehicle & Pedestrian Gates**

### Contents:

- Contractor Requirements
- Steps to Obtain Permits
- Installation Requirements for Manual Gates
- Knox Dual Padlock Locking System
- Manual Gate Signage
- Pedestrian Gates

### Purpose:

Emergency responders need uniform and dependable access through gates to deliver prompt service to the community.

---

**GATE CONTRACTOR REQUIREMENTS**



---

## LICENSE REQUIREMENTS

When installing, modifying or repairing a gate at any location that obstructs a fire apparatus access road, the gate contractor shall be licensed by the New Mexico of Contractors. Accepted licenses are C-14, R-14 or CR-14

---

## BUSINESS PERMIT CERTIFICATES

Contractors shall obtain a Business Permit Certificate from the Northwest Fire District prior to performing work within the District. Business Certificate Permits expire on December 31st and are to be renewed annually. Contractors in good standing are included on the New Mexico Approved Contractors List found on our website at [https://www.losalamosnm.us/government/departments/fire\\_department](https://www.losalamosnm.us/government/departments/fire_department)

---

## REQUIRED PERMITS and PLAN SUBMITTALS

A gate permit is required for all new gate installations.

Submit two (2) sets of plans along with a completed permit application for review to the appropriate location:

**Los Alamos County projects:** Los Alamos County Community Development  
Department  
1000 Central Ave. Suite ????  
Los Alamos, NM 87544

**Los Alamos Fire Department:** Fire Marshal Office  
999 Central Ave. Suite 200  
Los Alamos, NM 87544

---

## SITE PLAN REQUIREMENTS

In addition to specific requirements detailed in this guide, site plans shall include the following information:

- Name and address of the installing contractor.
- Project location including address and suite numbers, if applicable
- Orientation to streets, buildings and property lines
- Graphic representation of the scale used on the drawing
- Point of compass
- Number of gates to be installed and their locations



## INSTALLATION REQUIREMENTS FOR MANUAL GATES

1. All clear openings as shown on plans shall be a minimum 20 feet clear width for BIDIRECTIONAL access roads and 14 feet clear width or larger for UNIDIRECTIONAL access roads. If gating an existing drive, the current width of drive must remain as the original approved clear access width.
2. Turning radius shall comply with AASHTO WB-40 turning radius requirements. When a 45-foot turning radius cannot be met, the fire code official may require additional clearance.
3. All manual controlled gates that cross fire apparatus access roads or other roads to areas where immediate access is necessary for life saving or firefighting purposes (as determined by the Fire Code Official) shall use an approved dual padlock locking bar and an approved **KNOX PADLOCK SERIES #3770**. See **Chapter 4: Knox Boxes, Key Switches, Etc.** for Knox ordering information. See specific manual gate type included in Chapter 7 for dual padlock locking bar detail.
4. Fire Department approved “No Parking” signs shall be bolted back to back on each side of the gate(s). A total of 4 signs are required per gate. *See specific manual gate type included in Chapter 7 for sign placement detail.* See **Chapter 2: Fire Lanes and FD Access** for fire lane sign specifications.
5. When required by the Fire Code Official, a sign that identifies the location of the property's primary entrance shall be bolted on the street side of the gate(s). See **Chapter 7-6: Property Identification Access Sign Sample Detail** for sign detail.





## MANUAL ROLLING GATE DETAIL

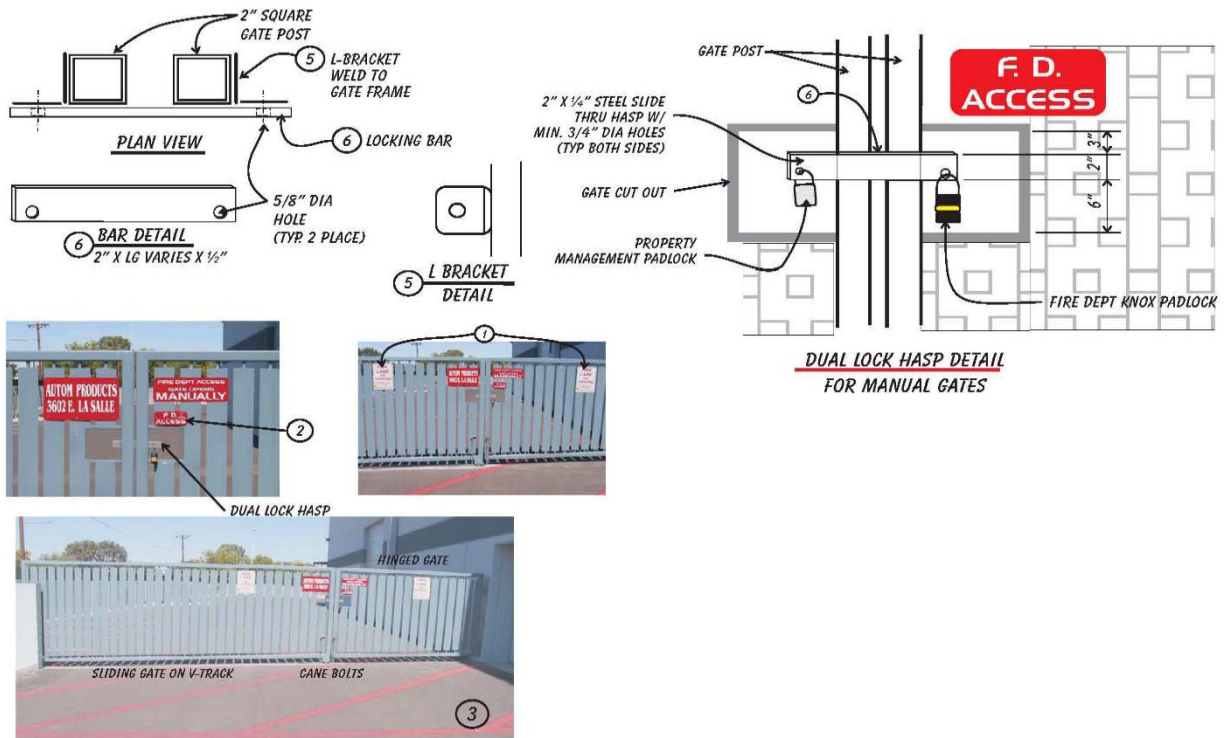

1. Approved fire lane signs with reflective background, placed back-to-back and fastened on all 4 corners. See **Chapter 2: Fire Lanes and FD Access** for sign specifications.
2. Approved Fire Department Access sign w/ reflective background placed back-to-back. See **Chapter 3-10: Fire Department Access Sign Detail** for sign specifications.
3. When required by the Fire Code Official, pavement striping shall be painted Safety Red with six (6) inch wide hash striping approximately 4 to 6 feet apart.
4. The minimum overall width of the gate opening shall be 20 feet.
5. Weld modified L-bracket to gate frame.
6. Locking bar length is determined by the frame width and gap width between the two gates. Remove all sharp edges/round all corners. Drill a minimum  $\frac{3}{4}$ " diameter hole. Hole diameter is determined by the padlock size.
7. See **Chapter 4: Knox Boxes, Key Switches, Etc.** for Knox key switch and Knox padlock information and ordering.



## SWING GATE WITH KNOX PADLOCK DETAIL

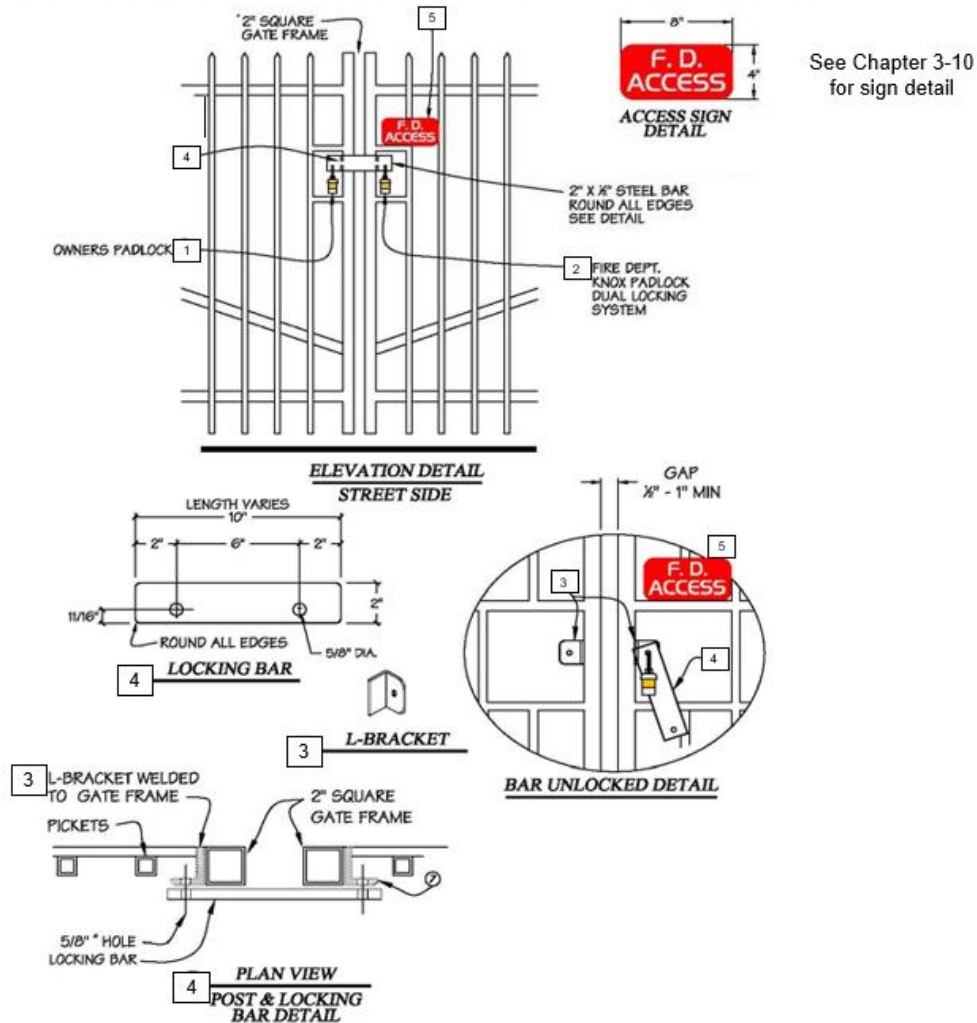

1. Property owner / management padlock.
2. An approved **KNOX PADLOCK SERIES #3770** series shall be accessible from both sides of the gate (entrance & exit). See **Chapter 4: Knox Boxes, Key Switches, Etc.** for Knox padlock information and ordering.
3. Weld Modifier L-bracket to gate frame. Round all edges & round all corners.
4. Locking bar length is determined by the frame width and the gap width between the two gates. Remove all sharp edges.
5. Approved Fire Department access sign with red reflective background placed back-to-back. See **Chapter 3-10: Fire Department Access Sign Detail** for sign specifications.



## ROLLING GATE WITH KNOX PADLOCK DETAIL

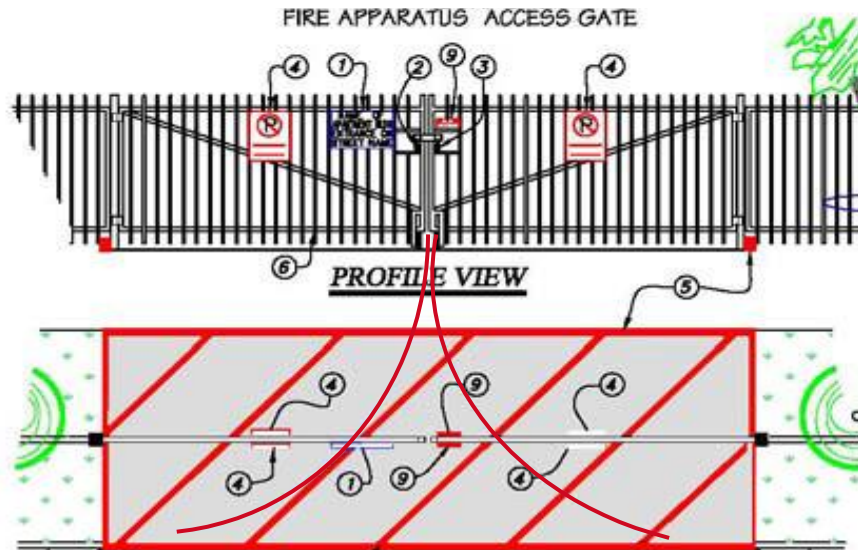

1. When required by the Fire Code Official, provide an approved sign, with reflective background, to identify the name of the complex or property and the location of the access entrance. See **Chapter 7-6: Property Identification Access Sign Sample Detail** for sign specifications. Sign requires pre-approval by the Fire Code Official.
2. Property owner / management padlock.
3. An approved **KNOX PADLOCK SERIES #3770** shall be accessible from both sides of the gate (entrance & exit). See **Chapter 4: Knox Boxes, Key Switches, Etc.** for Knox padlock information and ordering.
4. Approved Fire Lane signs with reflective background, placed back to back, and fastened on all four corners. See **Chapter 2: Fire Lanes and FD Access** for sign specifications.
5. When required by the Fire Code Official, six (6) inch parking lot striping shall be placed at the locations shown, on concrete curbs, and applied to asphalt.
6. The minimum overall width of the gate opening shall be 20 feet.
7. Weld Modifier L-bracket to gate frame. Round all edges & round all corners.
8. Locking bar length is determined by the frame width and the gap width between the two gates. Remove all sharp edges.
9. Approved Fire Department access sign with red reflective background placed back-to-back. See **Chapter 3-10: Fire Department Access Sign Detail** for sign specifications.



## PROPERTY IDENTIFICATION ACCESS SIGN SAMPLE DETAIL

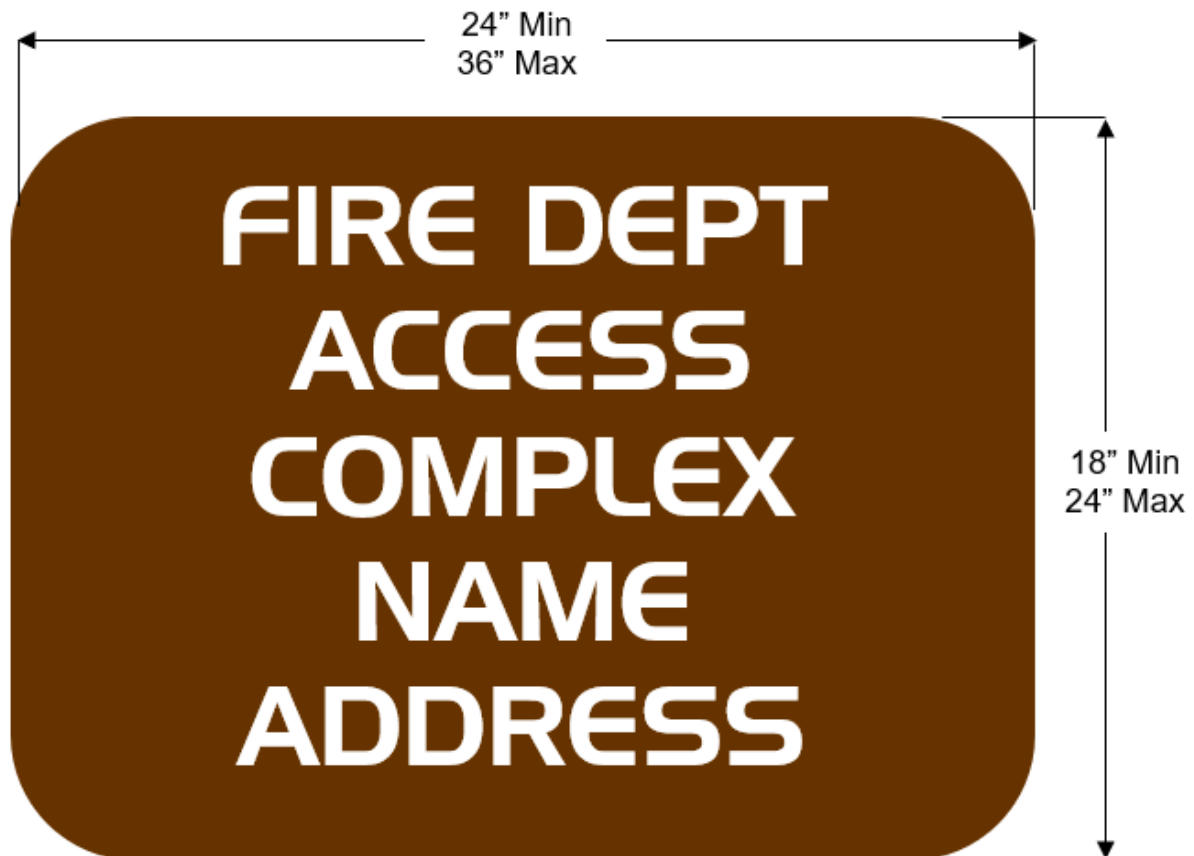

1. The sign face shall be a minimum of 18" x 24" with a maximum of 24" x 36" and fabricated from .080 aluminum sheet with 1 ½" radius corners.
2. Font style used is Handle Gothic BT Capital font.
3. The sign face shall have a white 3M diamond-grade reflective sheeting (3990 series VIP type IX) applied as a background.
4. Lettering/Graphics shall be one of the following:
  - a. 3M Scotchlite electronic transparent cuttable film (1170 series) inverse cut to allow white reflective background to show through lettering.
  - b. Screen printed using translucent ink.
  - c. Both processes (a or b) will accomplish a colored field with white copy.
5. Signage wording and color require pre-approval by the Fire Code Official.



## MANUAL CHAIN LINK SECURITY GATE DETAIL

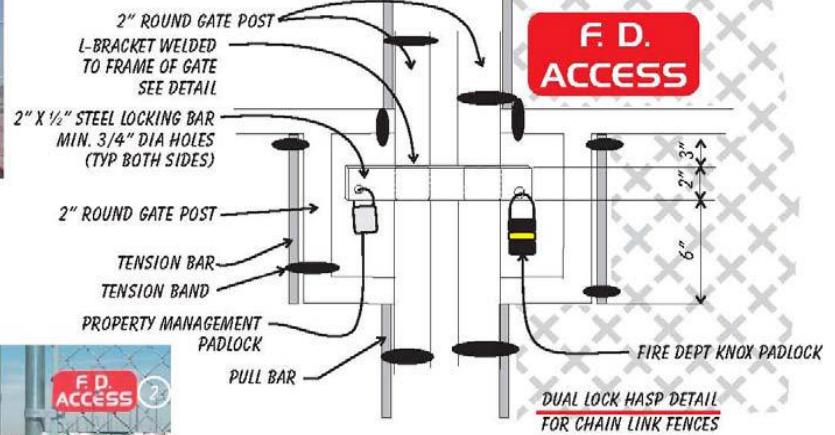
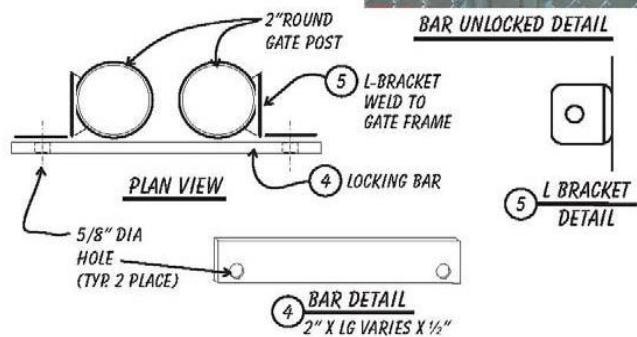
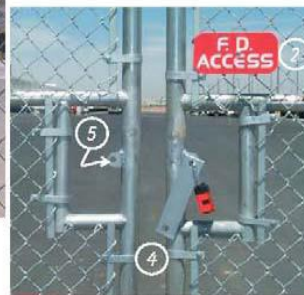

- Approved fire lane signs with reflective background, placed back-to-back and fastened on all 4 corners. See **Chapter 2: Fire Lanes and FD Access** for sign specifications.
- Approved Fire Department access sign with reflective background placed back to back. See **Chapter 3-10: Fire Department Access Sign Detail** for sign specifications.
- When required by the Fire Code Official, pavement striping shall be painted Safety Red with six (6) inch wide hash striping approximately 4 to 6 feet apart.
- Locking bar length is determined by the frame width and gap width between the two gates. Remove all sharp edges/round all corners. Drill a minimum 3/4" diameter hole. Hole diameter is determined by the padlock size.
- Weld Modified L-bracket to gate frame.
- The minimum overall width of the gate shall be 20 feet.
- An approved **KNOX PADLOCK SERIES #3770** shall be accessible from both sides of the gate (entrance & exit). See **Chapter 4: Knox Boxes, Key Switches, Etc.** for Knox padlock information and ordering.





# SINGLE SWING MANUAL SECURITY GATE DETAIL

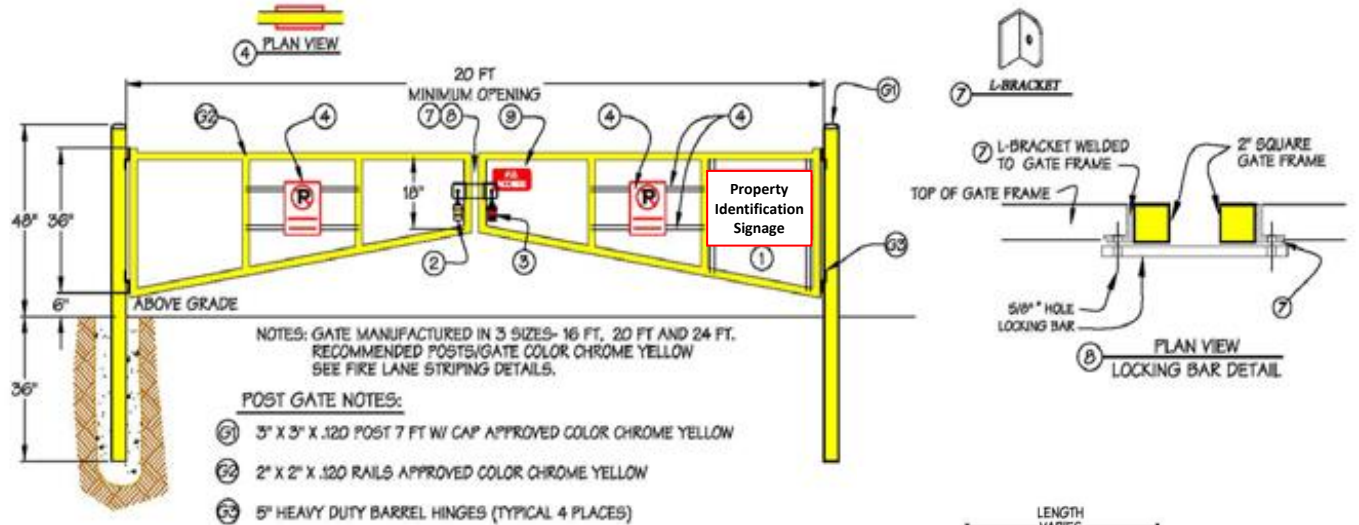

1. When required by the Fire Code Official, provide an approved sign, with reflective background, to identify the name of the complex or property and the location of the access entrance. See **Chapter 7-6: Property Identification Access Sign Sample Detail** for sign specifications. Sign requires pre-approval by the Fire Code Official.
2. Property owner / management padlock.
3. An approved **KNOX PADLOCK SERIES #3770** shall be accessible from both sides of the gate (entrance & exit). See **Chapter 4: Knox Boxes, Key Switches, Etc.** for Knox padlock information and ordering.
4. Approved Fire Lane signs with reflective background, placed back to back, and fastened on all four corners. See **Chapter 2: Fire Lanes and FD Access** for sign specifications.
5. When required by the Fire Code Official, provide 6-inch parking lot striping at the locations shown on concrete curbs and applied to asphalt.
6. The minimum overall width of the gate opening shall be 20 feet.
7. Weld Modifier L-bracket to gate frame. Round all edges & round all corners.
8. Locking bar length is determined by the frame width and the gap width between the two gates. Remove all sharp edges.
9. Approved Fire Department access sign with red reflective background placed back-to-back. See **Chapter 3-10: Fire Department Access Sign Detail** for sign specifications.

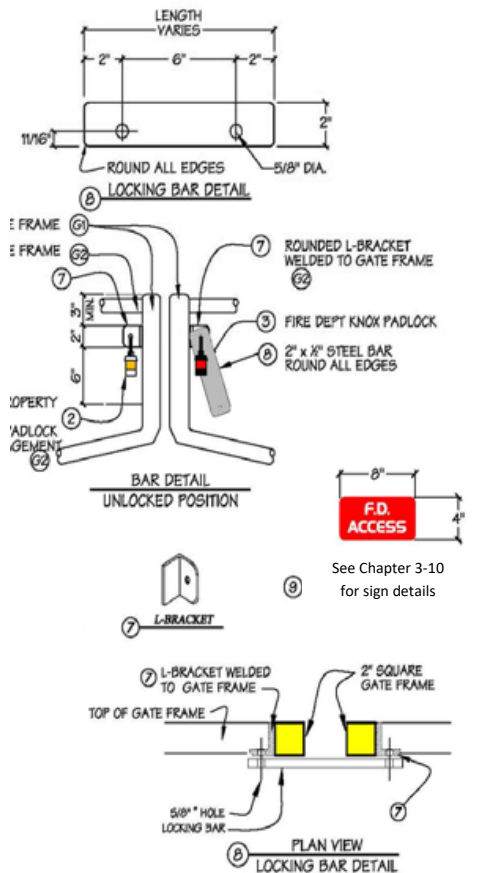



## APPROVED PEDESTRIAN GATE REQUIREMENTS

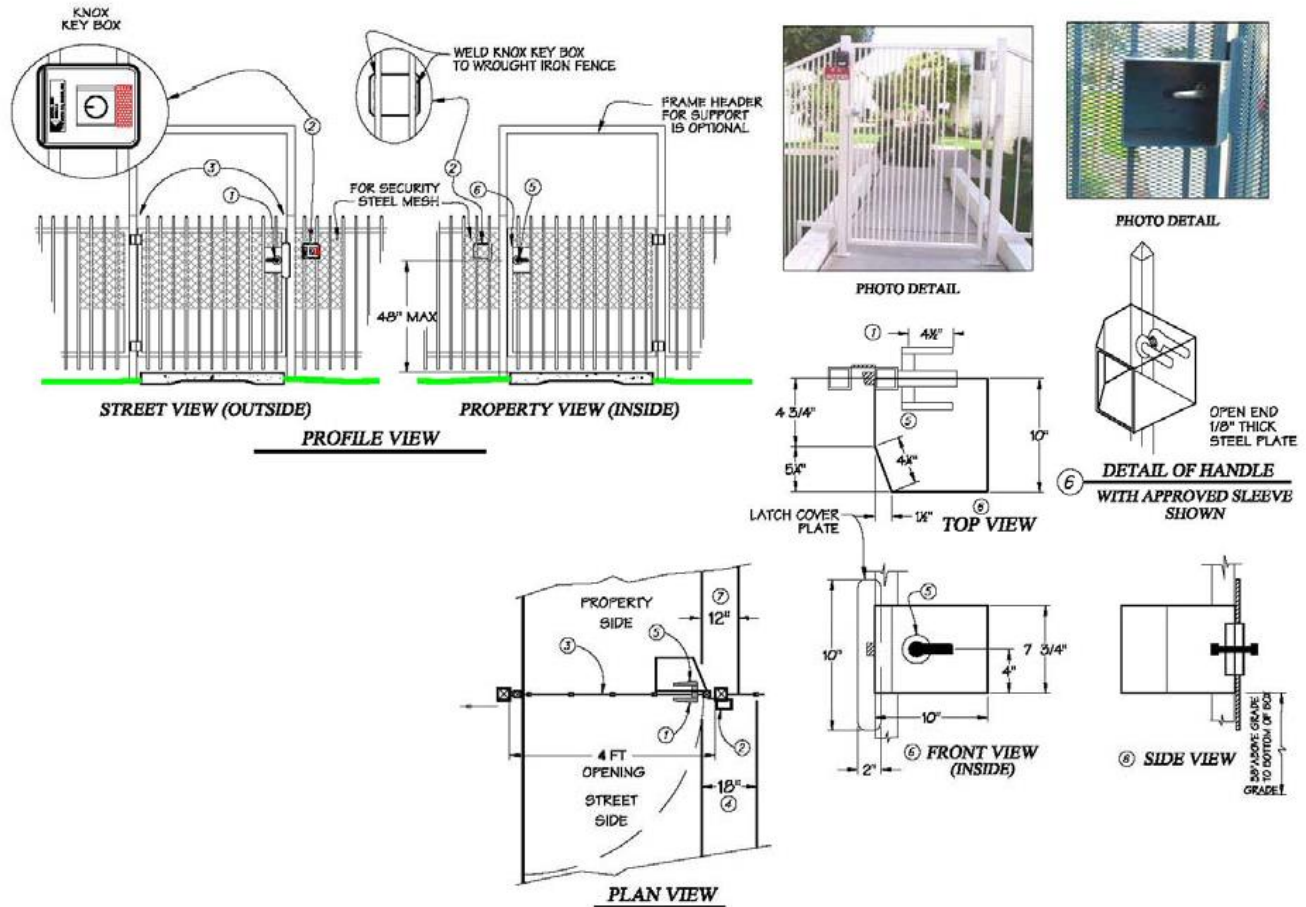

### Street side requirements:

1. Locking device on gate must operate with a key. Lock must face the street side.
2. Key to lock must be placed in an approved **KNOX BOX SERIES #3200** key box. Knox box must be welded on fence picket facing street. See **Chapter 4: Knox Boxes, Key Switches, Etc.** for Knox box information and ordering.
3. The minimum overall width of gate opening shall be 4 feet.

### Property side requirements:

4. Gate must enable exiting **without a key** or special knowledge.
5. An approved protection sleeve may be placed over the lever handle.
6. Width of concrete pad should be increased by 12 inches if the gate has a closer.



## KNOX BOX PLACEMENT FOR PEDESTRIAN GATES



1. Primary access points that have pedestrian gates require Fire Department access. Access may be provided using a **KNOX KEY SWITCH SERIES #3500** for electric gates or a **KNOX BOX SERIES #3200** key box for manual gates. See **Chapter 4: Knox Boxes, Key Switches, Etc.** for Knox box information and ordering.
2. The Fire Department will determine the final placement and number of Knox boxes required.

